

NT92H Series Omega™ Quick Couplings

Serving The Nuclear Industry



www.thorburnflex.com

(N)T92H Series - Dry Break High Pressure Quick Coupling

Prevents Resin Valve Blockage & Disconnection Spillage

Thorburn's (N)T92H is a major advancement in quick coupling technology achieving unrestricted full flow during operation and drip free double shut-off drybreak disconnection. The (N)T92H environmentally focused quick coupling system is specifically designed to prevent chemical spills, reduce vapor emissions of volatile organic compounds (VOCs) and enhance operator safety. Its full flow smooth bore design means better flow even for highly viscous fluids.

The (N)T92H coupling system consists of a female end having a concave ball valve and a male end having a convex ball valve that are precision machined to eliminate any spaces between the ball valves. A quarter turn of the ball valve securely seals the process fluids within the line. The (N)T92H coupling can even provide a seal when solids are suspended in the media such as radioactive D₂O resins in PHWR nuclear power stations. Thorburn's (N)T92H has a built-in swivel end that eases alignment regardless of pipe or hose orientation and has a unique locking mechanism that prevents accidental spillage. It is ideally suited for tank truck and tank car transfer systems where environmental compliance is not an option and operator safety is a company culture.

Features

- **Zero spillage** during disconnection eliminates hazardous chemical waste pollution even when solids are suspended in the media.
- **Unrestricted high flow** during operation reduces pressure drops.
- **Eliminates chemical waste** incineration and disposal costs.
- **Reduces liability exposure**, loss time and worker compensation claims.
- **Built in swivel** eases alignment regardless of hose orientation.
- **Protects the installation assets** from hazardous waste product.
- **Prevents radio active D₂O resin blockage** between the valves in a PHWR nuclear power station.

Advantages

- Easy push & turn connection
- The valves cannot be opened when coupling is disconnected
- The coupling cannot be disconnected when the valves are open
- Reliable dry break with poppet valves

Applications

- Transfer of LIN/LOX/LAR, CO₂, Nitrous Oxide & LNG
- Loading/unloading of tank trucks, rail tankers
- Container discharge
- Fuel bunkering
- Vapor recovery lines

(N)T92H For Cryogenic Unloading

Thorburn's (N)T92H series is the worlds first dry break full flow coupling used for liquid cryogenic loading/unloading service. A sensational innovation over the poppet style cryogenic coupling which has inherent spillage when disconnected. The (N)T92H coupling has an easy turn action to connect and start the product flow. The full unrestricted flow will dramatically increase loading and unloading productivity of cryogenic liquids. The dry break technology will protect the environment and the operator's safety.

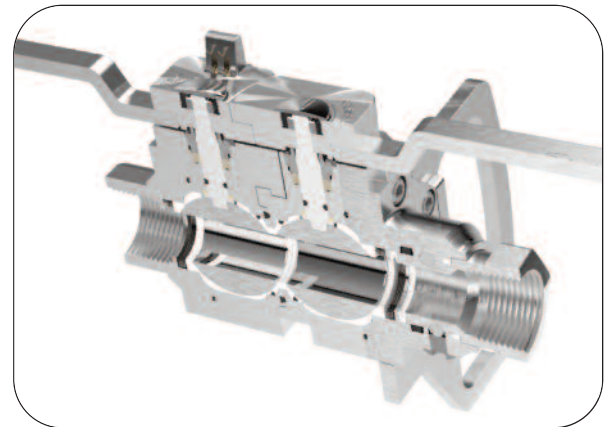
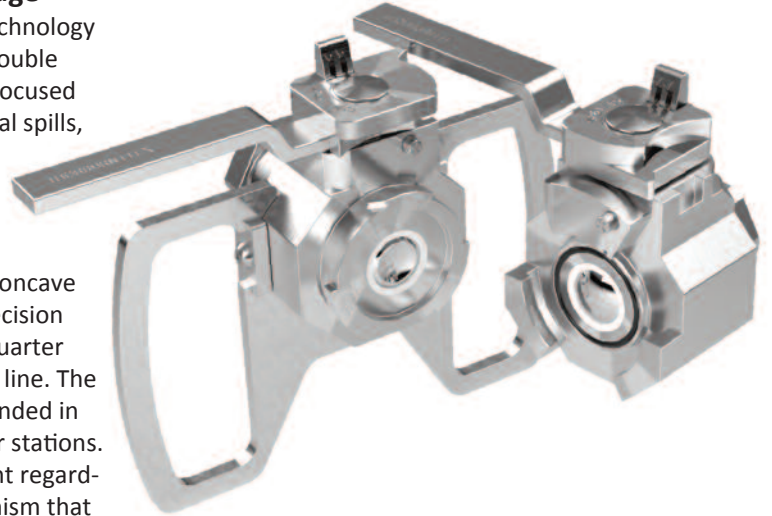

Unrestricted full flow reduces pressure drop during operation



Thorburn's NT92H dry break couplings ideal for cryogenic LNG tank truck loading/unloading. Available with tank truck & railcar flanges

(N)T92H Built In Safety Features

Thorburn Flex (N)T92H is a dry break, zero leak, quick coupling, with mating convex and concave ball valves on each side of the coupling. The (N)T92H unique design features provide up to five levels of independent safety mechanisms to prevent spills and accidental release of dangerous contaminants in the environment. The safety features are based on a combination of locking mechanisms that prevent wrong operation of the coupling by allowing only the preset sequential operation.



- **Ball Valve Zero Gap System** (Convex (male end) & Concave (female end)) prevents hazardous chemical loss during disconnection.
- **Valve Handle Locking System** locks the handle in the off position to safeguard against accidental opening when disconnected.
- **Safety Locking Mechanism** incorporates a Valve Handle Safety Locking Pin to prevent accidental openings.
- **The Locking Pin** is guided by the Valve Handle on the male end coupler.

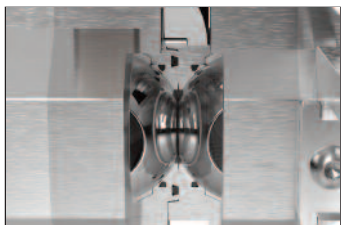

Ball Valve "Zero Gap" System

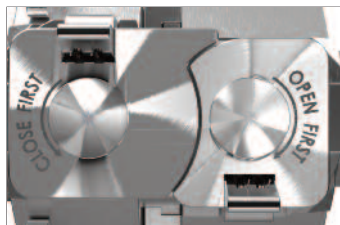

Valve Handle Locking System



Safety Locking Mechanism

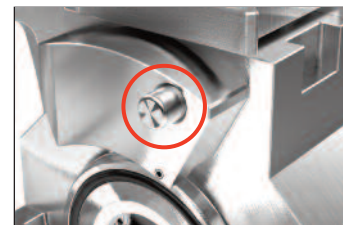

Locking Pin

(N)T92H Performance Characteristics

Adapter/Coupler Size		End Size		Spillage	Maximum Emissions	Flow Rate		Max. Working Pressure (min. 4-1 Safety)		Weight				Temperature			
										Male		Female		Min		Max	
in	mm	in	DIN	cc	ppm	GPM	l/min	psi	bar	lb	kg	lb	kg	°F	°C	°F	°C
1	25	3/4, 1	20, 25	< 0.1	< 25	60	227	3000	207	4.02	1.82	4.23	1.92	-459	-273	400	204
2	50	1 1/2, 2	40, 50	< 0.2	< 25	180	681	1800	124	17.45	7.92	17.44	7.91	-459	-273	400	204
3	80	3	80	< 1	< 25	350	1325	1000	69	33.70	15.2	30.65	13.9	-459	-273	400	204

Problematic Quick Disconnect Coupling Technologies



Cam & Groove Type = Spillage



Ordinary Ball Valves Added = Spillage

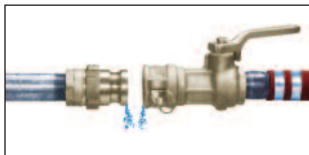

Traditional Poppet Valves = Spillage

Cam and Groove type couplings are incapable of avoiding spillage and vapor leakage upon disconnection. They are prone to accidental disconnects, which can be expensive and extremely hazardous.

Ordinary Ball Valves, added to quick couplings to shut off the flow, allow trapped liquid between the hose and the adapter to flow freely on to your plants floor or your employees hands upon disconnection.

Traditional two-way poppet valve style dry break couplings by its very design are predisposed to spills because of the unavoidable liquid that is trapped in the gap between the coupler poppet valve and the adapter poppet valve upon disconnection.

THORBURN FLEX - Canada
 165 Oneida, Pointe-Claire, Quebec
 Canada, H9R 1A9
 Tel: +1-514-695-8710
 Fax: +1-514-695-1321
 sales@thorburnflex.com



ISCIR Romania | CNCAN Romania | EN 13480-2002 | HAF 604 China | TSG China
 (CRN for all Canadian Provinces)

(N)T92H Sealing Technology

Cavity Filler - Prevents flow accumulation between ball valve and coupling body. Reduces spillage when disconnecting and prevents solids from being trapped between the rotating ball valves.

Ball Valve Seal - Flexible arch shaped ball valve seal provides constant sealing pressure and compensates for machining tolerances.

Spring Enhanced O-Ring Seal - Puts constant pressure around the stem and eliminates leaks through the valve handle stem.



Cavity Filler



Ball Valve Seal

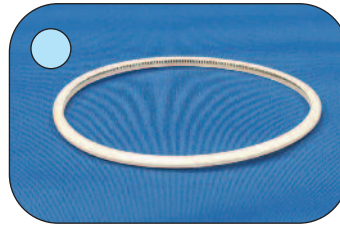

Spring Enhanced O-ring Seal

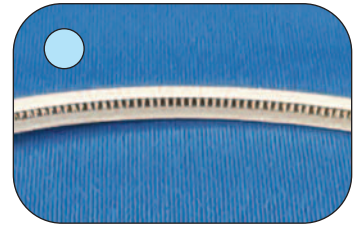

Detail of The Spring in the O-ring Seal

(N)T92H Easy to Operate Dry Break Solution

The (N)T92H coupling has an easy turn action to connect and start the product flow. The valves will not open until both coupling halves are connected properly. The coupling halves are first aligned and then connected with a push, followed by a quarter turn. There are no threads to damage by over tightening and no failure prone cam and groove latch connections to secure. The coupling halves are independent "shut off" ball valves that are controlled manually by rotating the valve handles in a specific sequence.

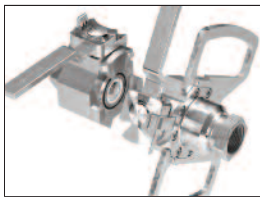

Align coupling halves

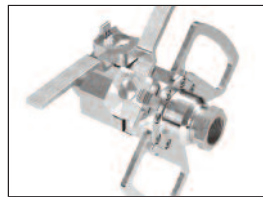

Push together & turn 90°

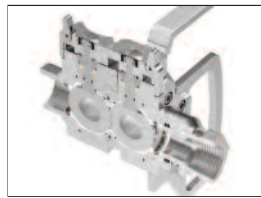

Coupling connected & locked

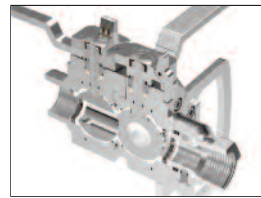

Open male end valve

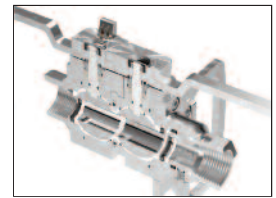

Open female end valve

The (N)T92H can only be disconnected when both the valves are shut off in sequence; female end valve first and then male end valve second. This ensures zero spillage and protects against accidental disconnection.



www.thorburnflex.com